



Munters EM 50-52

Air extraction fans

The EM Series, the most well-known box fan family designed and produced by Munters, since the 1980s has delivered excellent performance in any livestock farming (broiler, layer, swine, dairy) and greenhouse application.

Features

- Superior durability with Munters Protect coating, 3 years warranty against corrosion
- Reliable, proven in the market for 40 years
- Light and air draft reduction, when shutter is closed
- Energy efficient solution
- Suited for tunnel ventilation

Munters EM 50-52 are the ideal exhaust fans whenever extra high airflow capacity is required, even in high static pressure environments, thanks to their unique propeller shape that ensures full efficiency and reliability.

Munters EM Series features the housing, conveyor and shutters made in Munters Protect coated steel for extra strength and resistance against corrosion. Central hub and v-belt pulley are made of die-cast aluminum with reinforced ribs for long-lasting use.

The belt drive system enables low speed propeller, which results in reduced energy consumption and noise level, assuring a comfortable environment for both animals and operators.

The patented centrifugal system provides an energy efficient solution and powerful springs keep shutters tightly closed when the fan is not turned on, avoiding air leakage and blocking light.

Munters EM 50-52 undergo strict quality control and performances are validated by tests carried out in BESS Lab at the Agricultural Engineering Department of University of Illinois (USA).

As market leader in ventilation solutions for more than 60 years, Munters guarantees quality and is ISO 9001 certified.



EM50 front view

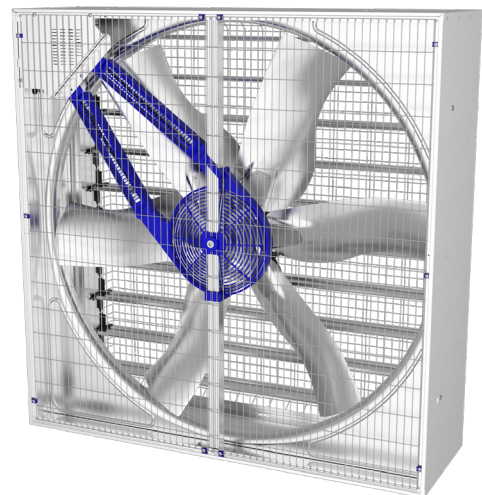

EM52 rear view

Munters EM 50-52

Air extraction fans

Dimensions

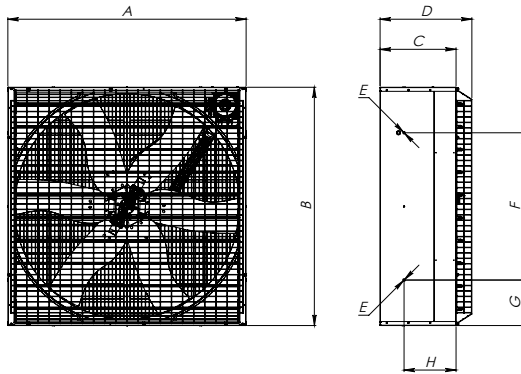

	EM50	EM52
A	1380 mm	1425 mm
B	1380 mm	1425 mm
C	450 mm	455 mm
D	540 mm	545 mm
E	M8	M8
F	830 mm	830 mm
G	275 mm	298 mm
H	308 mm	310 mm

Technical specifications

		EM50		EM52
		1.0	1.5	2.0
Nominal power	Hp	1.0	1.5	2.0
Propeller diameter	mm [inch]	1270 [50]		1334 [52]
Number of blades/material		6/Munters Protect		6/Munters Protect
Number of shutter blades		10		10
Transmission		Belt drive		Belt drive
Weight of fully equipped fan	kg	84	86	90
Max power consumption/max current ¹	W/A	1150/2.1	1810/3.3	1770/3.5
Max operating temperature	°C [°F]	50 [122]		50 [122]
Max operating pressure	Pa	50		100
Motor insulation grade/protective class		F/IP55		F/IP55
Noise level ²	Db(a)	67.6	70.4	70.3

¹50 Hz 400 V specification, 60 Hz available upon request, ²Noise measure made according to ISO 3744

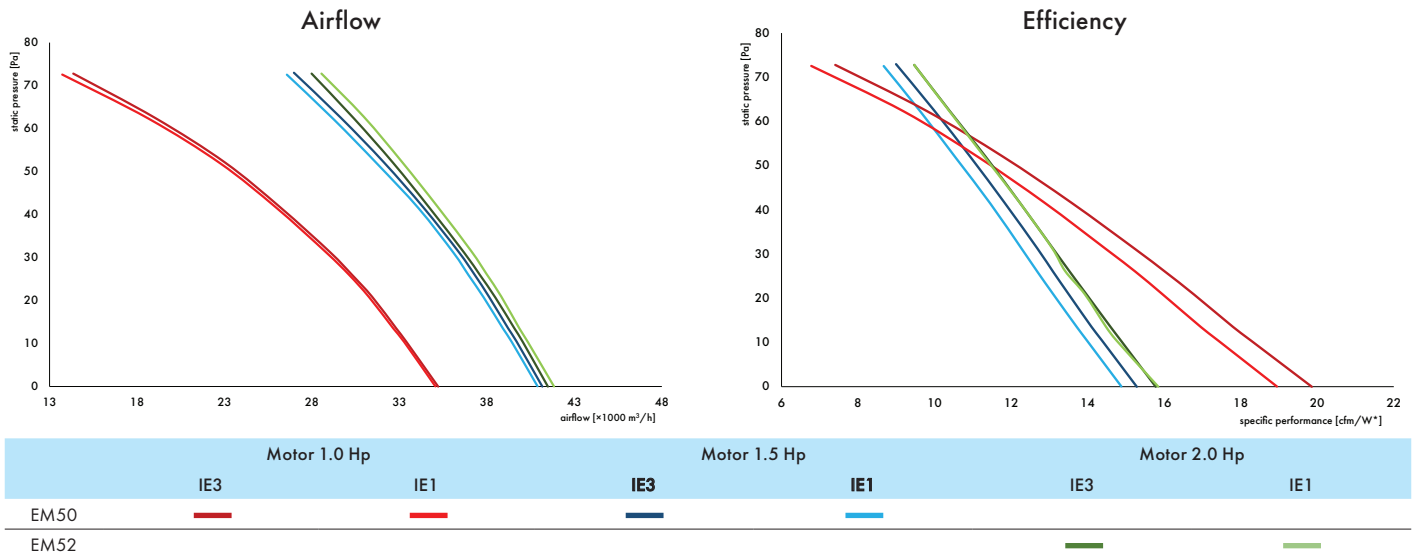

Airflow and efficiency data measured at standard conditions (20°; 1013 hPa). *1 cfm/W = 1.7 m³/hW

Load capacity

	EM50		EM52	
	Unassembled	Assembled	Unassembled	Assembled
20' Container	170 (120 ¹)	24	120	24
40' Container	-	49	-	49
40' HC Container	300	57	300	57
Truck	328	65	328	64

Pyramidal mesh for installation below 2.7 m available upon request. ¹With CE plastic protection

Find your nearest Munters office at www.munters.com

Munters reserves the right to make alterations to specifications, quantities, etc., for production or other reasons, subsequent to publication. © Munters AB, 2021